

RF Lite[®] Friction edition

Entry-level system for the automatic coding of flat-form cartons and sleeves

The RF Lite Friction Edition uses rollers to guide the packaging underneath the printer, ensuring accurate code placement, every time. The compact system utilises maintenance-free thermal inkjet technology to produce crisp, consistent prints at impressive speeds.



High-resolution

Fitted with a thermal inkjet printer, the RF Lite can print excellent quality (up to 600dpi) text, barcodes, logos and more.



Operator friendly

Easy to use, minimal training needed. Printer requires no maintenance and cartridges are changed in seconds.



Increased efficiency

Ideal for automating the coding process for the first time. Allows labour to be utilised elsewhere in production.



Cost-effective

Comparatively low upfront cost. Excellent return on investment (ROI). One system can serve multiple lines.

Made in Britain

Along with all of our other feeding and handling systems, the RF Lite has been carefully designed, engineered and manufactured here in our Hertfordshire factory; something unique to us that we are incredibly proud of.

As a one-of-a-kind off-line coding system, the RF Lite has not only helped us to expand our product range, but it has also assisted many small UK businesses in their growth, allowing them to scale up their coding processes alongside increased demand. Now some of those businesses aren't so small anymore.



To book a free demonstration, call **+44 (0) 1707 393 700**
or email sales@rotechmachines.com

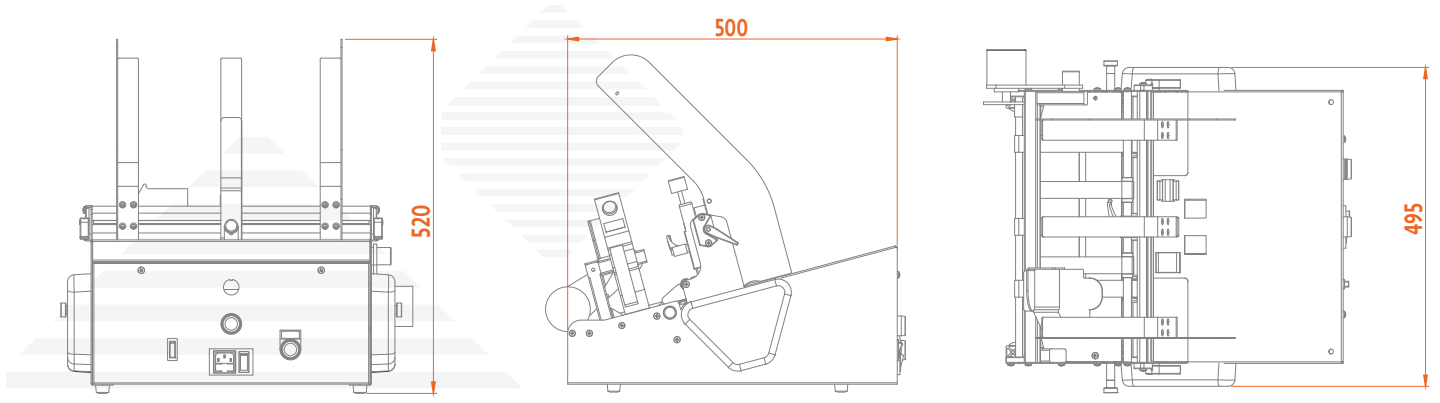

PRODUCT SPECIFICATIONS

RF Lite Friction Edition

Footprint (L x W x H)	Without outfeed catcher	500 x 495 x 520 mm
	With outfeed catcher	800 x 495 x 641 mm
Weight	Without outfeed catcher	20 kg
	With outfeed catcher	22 kg
Packaging dimensions	External packaging dimensions	600 x 600 x 580 mm
	Gross weight (max)	30 kg
Product sizes	Minimum	60 (leading edge) x 50 mm
	Maximum	300 (leading edge) x 200 mm
	Product thickness - minimum	80g/sqm
	Product thickness - maximum	2.5 mm
Throughput	Recommended daily throughput	Up to 14,000 products
	Max product throughput	400 per minute
Speed	Low speed	20 m/min
	High speed	60 m/min
Controls	Start	Pushbutton (green)
	Stop	Pushbutton (red)
	Reset	Pushbutton (white, illuminated)
	Speed selector (high/low)	Toggle/rocker switch
	Product gating adjustment	Knurled screw and locking lever 0 - 2.5 mm (0.25 mm adjustment per 360 ° rotation)
Hopper adjustments and capacity	Manually adjustable on side	Single lock levers - both hoppers
	Minimum width	30 mm
	Maximum width	300 mm
	Infeed hopper capacity	350 mm
Outfeed belts	Central belt 25 mm wide	Fixed position
	2 x outer belts 25 mm wide	Individual adjustment to suit product width
Electrical	Inlet: 240/115 vac 50/60 Hz	Switched IEC C14 socket to rear control panel Fused 2A
	Outlet: (Printer supply) 240/115 vac 50/60 Hz unfused	IEC panel mount C13 socket printer supply not to exceed 1.5A
Other	Printer mounting (Standard)	TIJ (other printers on request)
	Encoder mounting	Optional - details on request
	Optional extras	Shingling conveyor

To book a free demonstration, call **+44 (0) 1707 393 700**
or email sales@rotechmachines.com

DS.RFLF.2024.2